

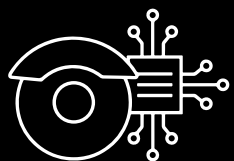

BREMBO
AFTERMARKET
PRODUCTS
& SOLUTIONS



OUR BUSINESS UNITS



SYSTEM

Original equipment for passenger cars and light commercial vehicles

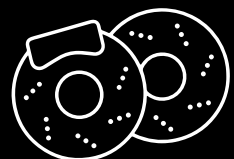

DISC

Original equipment for passenger cars, LCV and heavy duty vehicles

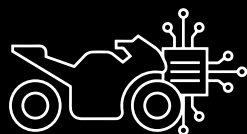

MOTORCYCLE

Original equipment and aftermarket for motorcycles



AFTERMARKET

PASSENGER CARS AND LIGHT COMMERCIAL AFTERMARKET PARTS

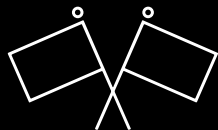

PERFORMANCE

Racing, upgrade and specialty OE brake systems for cars and motorbikes

AFTERMARKET PRODUCTS WITH OE QUALITY

In compliance with European safety regulations, certified in observance of all the strictest international standards, Brembo checks all phases of the production process: design, development, testing, casting, processing, assembly, distribution and assistance.

The production of original components is carried out in production plants approved by the car manufacturers; **Brembo manufactures Aftermarket products** in the same plants, therefore Aftermarket products have the **same high technological value as the original components**.



OUR VISION

TURNING ENERGY INTO INSPIRATION

In the nowadays' world scenario, being able to **control energy** is a superpower. But for **Brembo** is not enough. **It turns it into inspiration**: pioneering ideas that can open new horizons.

We innovate by harnessing energy through **tailored solutions** that integrate data with heritage, digital with real, intuition with action.

Turning energy into inspiration means also helping new generations by reducing the environmental impact.

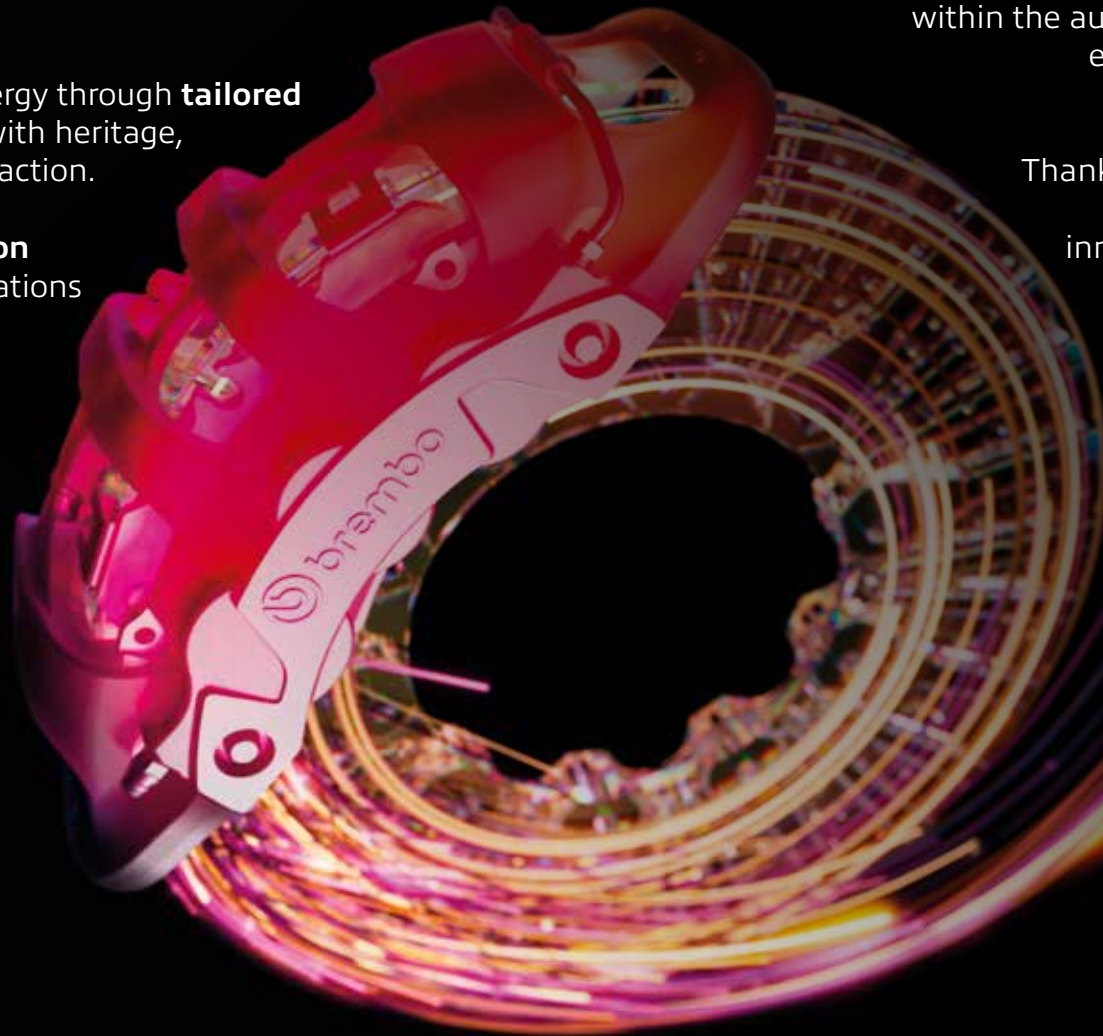

OUR POSITIONING

CUTTING-EDGE SOLUTIONS FOR THE NEW MOBILITY

Our mission as a solution provider is to leverage data to offer integrated services and products, by foreseeing the customers' wishes within the automotive industry megatrends: electrification, digitalization and autonomous driving.

Thanks to data analysis and artificial intelligence, we can enhance innovation and offer personalized driving experiences.

Our pillars:

GLOBAL ●
COOL ●
DIGITAL ●

OUR LOCATIONS

The company expansion has enabled Brembo to deliver its technology **across the globe**. We can now call **the world our home**.

○ 23 INDUSTRIAL SITES

• 15 COMMERCIAL SITES

● 07 RESEARCH AND DEVELOPMENT CENTERS

● 01 BREMBO INSPIRATION LAB

- 
- BRAZIL
 - CHINA
 - CZECH REPUBLIC
 - DENMARK
 - GERMANY
 - INDIA
 - ITALY
 - JAPAN
 - MEXICO
 - POLAND
 - RUSSIA
 - SPAIN
 - SWEDEN
 - UNITED KINGDOM
 - UNITED STATES

BREAKTHROUGH TECHNOLOGY

We strongly believe that the **research of today** turns into the **solutions of tomorrow**, and technology is our biggest ally.



A STYLE ICON

Beauty and function harmonize perfectly in Brembo. We always supervise the design of each product in synergy with its functionality and safety: a sign of personality and a prestigious signature recognized by many.



OVERCOMING LIMITS

**MOTORSPORT IS PART OF
WHO WE ARE.
WE BELIEVE THAT EVERY RACE
IS THE CHANCE TO OVERCOME
NEW LIMITS AND IGNITE PASSION.**

Since the encounter with Enzo Ferrari, Brembo enables race drivers and their fans to experience the top braking performance at the highest levels of safety. We compete on the most challenging race circuits in the world and won more than 600 titles.



 **brembo**
RACING



THINKING RESPONSIBLY. ACTING CONCRETELY

ESG is part of Brembo's corporate strategy: daily concrete practices are designed to balance business decisions against an assessment of their social and environmental impact, while always taking account the expectations of all stakeholders.

We adhere to the UN 2030 Agenda and its 17 Sustainable Development Goals. Environmental, Social and Governance values drive Brembo towards an increasingly inclusive and responsible future. Sustainability disseminates through any idea, in every process, product and solution.

OUR PEOPLE OUR PLACE

Brembo people are our most valuable resource. With their passion and skills, they are the true pillar of our strategy.

We guarantee the respect of human rights and working conditions. We invest in constant training and promote an increasingly inclusive environment.

We build deep ties with the local communities where we operate, contributing to a path of joint development and growth based on their needs. Brembo's social projects support childhood, education and training, art, culture, sport and scientific research.

THE WORLD WE WANT THE PLAN WE HAVE

We constantly commit to have a sustainable approach and reduce the impact on the environment. In everything we do, we are committed to reducing the consumption of natural resources and our carbon footprint.

In recognizing this commitment, CDP-Carbon Disclosure Project has awarded Brembo with a double A in the Climate Change and Water Security. Our challenging ambition is to achieve Net Zero emissions by 2040.





Essential

STANDARD LINE
BREMBO QUALITY
FOR THE ENTIRE
BRAKE SYSTEM



Prime

PREMIUM LINE
BEST FIT FOR
ANY VEHICLE

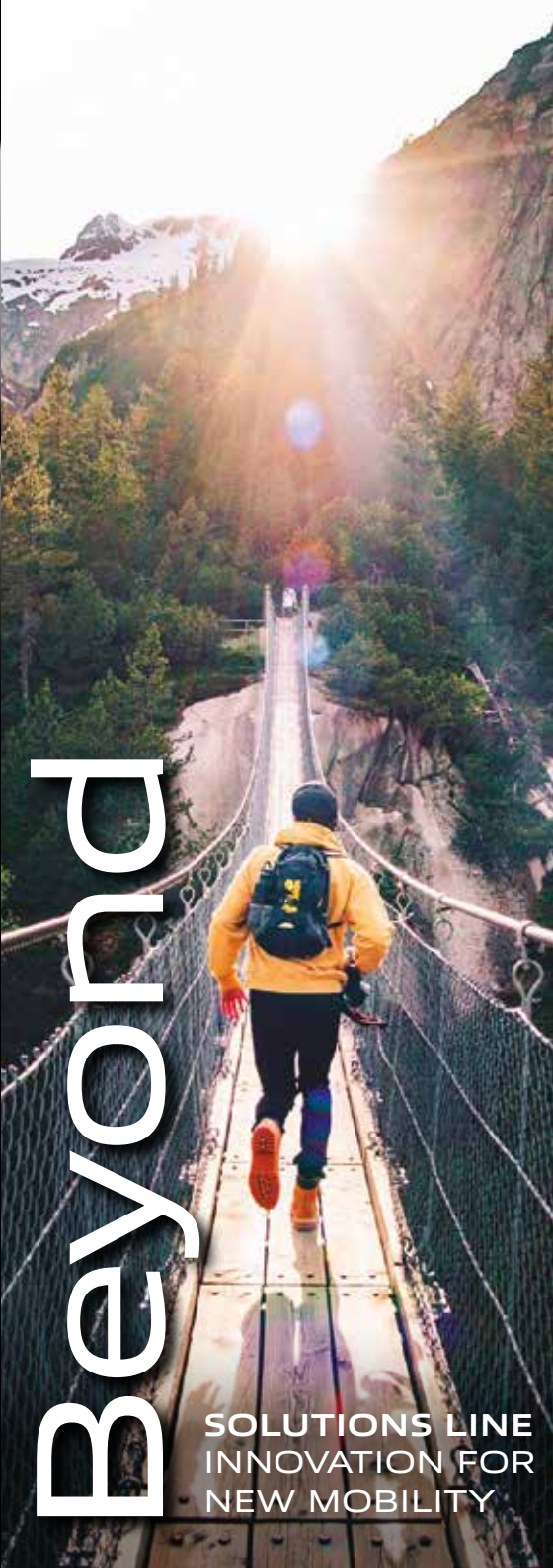

Beyond

SOLUTIONS LINE
INNOVATION FOR
NEW MOBILITY



Xtra

COOL LINE
DISTINCTIVE
PERFORMANCE

PRIME LINE

PREMIUM LINE • THE BEST FIT FOR ANY VEHICLE

PRIME BRAKE DISCS

98% CAR PARC COVERAGE

The control over the entire production cycle allows Brembo to offer a brake disc range with excellent performance, reliability, durability, and comfort in all conditions.



COMFORT

High Carbon: cast iron brake discs with higher carbon content to **minimise vibration** and noise, maximise **performance** and increase driving comfort.



PERFORMANCE

Exclusive and **patented Pillar Vented System** which enhances cooling potential and increases disc resistance.



TIME SAVING

Discs with factory preassembled **original bearings**, ready for immediate installation.



PROFESSIONAL INSTALLATION

Discs are supplied with all the **necessary fixing hardware**, for a simpler and safer installation.



UV PAINTING

A technology developed in collaboration with car manufacturers for more practical fitting procedures and **greater resistance to corrosion**.



WHICH ARE THE TECHNICAL FEATURES OF A BRAKE DISC?



PRIME BRAKE DISCS

MATERIALS & DESIGN

— MATERIAL — HAT CONNECTION — VENTILATION —



BREMBO	<ul style="list-style-type: none"> • 40 different types of material • Compliant with OE specification • Production process, integrity and mechanical characteristic in control 	<ul style="list-style-type: none"> • Compliant with OE specification • FEM analysis 	<ul style="list-style-type: none"> • Different type of ventilation • PVT ventilation patent by Brembo
AFTERMARKET GENERIC	<ul style="list-style-type: none"> • 1 or 2 type of materials • Low mechanical characteristic 	<ul style="list-style-type: none"> • No experience in OE • Design based only on the reverse engineering 	<ul style="list-style-type: none"> • No PVT available
RISKS	<ul style="list-style-type: none"> • Increased temperature • Increased cracks and possible breakage • Noises 	<ul style="list-style-type: none"> • Plastic deformation of the braking surface • Judder and noises 	<ul style="list-style-type: none"> • Increased temperature • Increased cracks • Noises, hot spot, wear

MATERIALS

HIGH CARBON

Brembo always uses the same material for its aftermarket disc production as used by the original manufacturer.

High Carbon cast iron, compared to the standard materials used, offer the following advantages:

 **Higher damping coefficient** that decreases the amount of vibration and noise, improves brake behaviour and ensures **better driving comfort**

 **Better heat conduction properties** that allows the faster transfer of heat from the braking surfaces to other surfaces and **shortens cooling times**

For **sports products** (Max and Xtra discs), special alloy high carbon materials are produced and tested to have **greater resistance to the thermo-mechanical stress** to which the brake disc is subjected.



UV COATED DISCS

INNOVATIVE BREMBO UV COATING TECHNOLOGY

Brembo is the first to offer UV coating technology engineered for leading OE customers with a unique metallic finish developed exclusively for the Aftermarket.

FEATURES AND BENEFITS

UNIQUE APPEARANCE

Metallic finish that maintains a clean and bright appearance over the entire life span of the disc.

BROAD RANGE

More than 1.900 items to satisfy most important applications on the market.

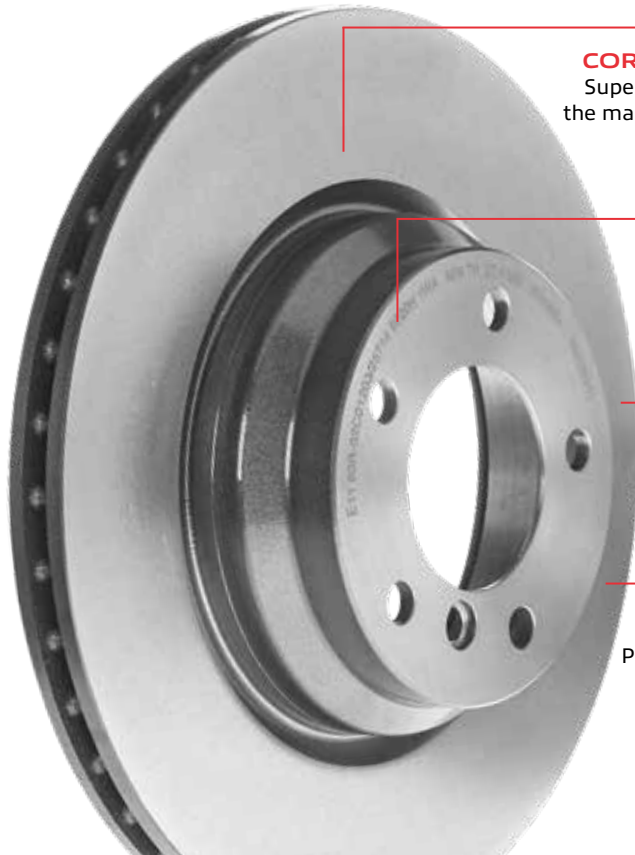

CORROSION RESISTANCE

Superior to products currently on the market proven by resistance to:

- Salt spray testing
- Humidity
- High temperatures

INTELLIGENT MARKING

New location for minimum thickness control with greater ease of reading for service professionals.

RESPECT FOR THE ENVIRONMENT

Water-based paint free of chemical solvents.
Energy efficient UV coating process.

SURFACE PROTECTION

Protective coating on braking plate surfaces, external diameter and disc hub to ensure complete protection.

SALT SPRAY TEST

CORROSION RESISTANCE 240 HOURS

The discs are tested in a salt spray chamber with continuous spraying according to UNI ISO 9227 for a minimum period of 240h at a temperature of 35°.

PURPOSE OF THE TEST

After the salt spray test, check the presence of rust in the areas not subject to contact with the brake pad.

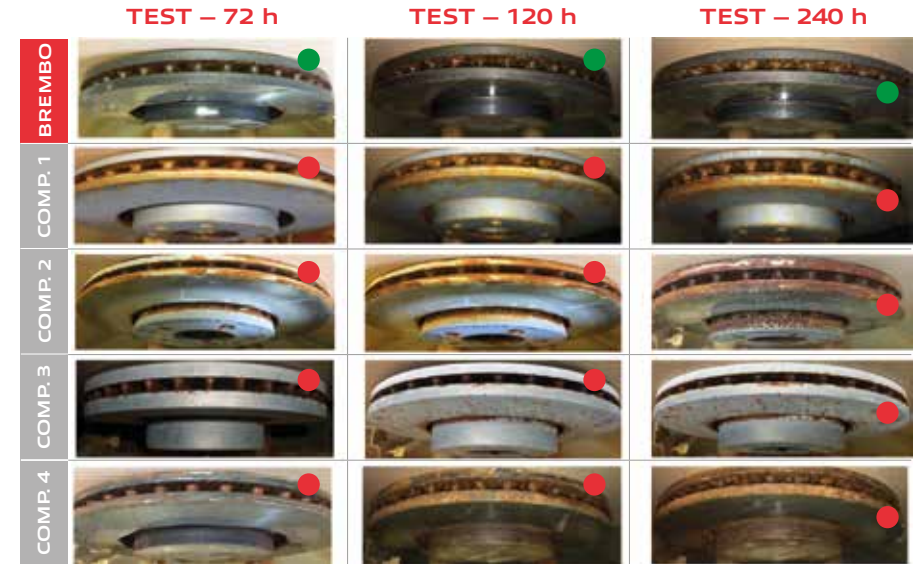

TWO-PIECE BRAKE DISCS

THE SPECIFIC RANGE FOR PREMIUM CARS

Always a point of reference as a supplier of top range Original Equipment for the most prestigious car manufacturers, Brembo naturally transfers this know-how to the Aftermarket with its most exclusive products, including the Composite, Floating, Co-cast, Lightweight and Dual Cast discs.

In all cases the most performing technical solutions are proposed to the market, such as:

- special cast iron
- pillar or directional venting
- drilled and/or grooved braking surface

Thanks to these technological solutions, Brembo guarantees the highest performance even in extreme conditions, greater resistance of the discs, optimum comfort during driving and a weight reduction of the braking system that can range from 15 to 30% compared to an integral one of the same dimensions.

This translates into a **reduction in consumption and emissions.**

The range covers the premium models of some of the most important car manufacturers.



FLOATING DISC

COMPOSITE DISC

CO-CAST DISC

LIGHTWEIGHT DISC

DUAL CAST DISC

PRIME BRAKE PADS

THE PERFECT PARTNER

The Brembo range of brake pads ensures **maximum safety** when braking thanks to **absolute control of all production stages**.

From research and development to testing, passing through **production of the friction compound and mechanical processing**.

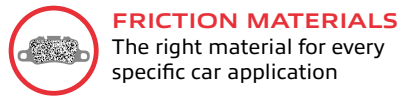

FRICITION MATERIALS
The right material for every specific car application



FITTING ACCESSORY KIT
To ensure problem-free installation



CHAMFER AND SLOT
To ensure comfort and performance



SPECIAL SOLUTIONS
Scorching, weight and directionality to prevent fading and minimize noise and vibration



ANTI-NOISE SHIM
The best multi-layer solution for every part number



ENVIRONMENTAL FRIENDLY
Ecological friction materials



WEAR INDICATOR
Complete set composition, according to OE

PREMIUM FEATURES

FRICITION MATERIALS

Component mix, compressibility and friction coefficient help to identify performance, comfort and wear of a friction material

DAMPING WEIGHTS

Brembo patented solution to minimize brake noises

MARKING

All the needed information



BACKING PLATE

With different anchoring systems for friction material

DESIGN

The presence of chamfers and slots to reduce noise and increase flexibility and cooling

PISTON INTERFACE

Multi-layer shims have the ability to reduce noise



BREMBO PRIME & BREMBO PRIME CERAMIC

BREMBO PRIME

- In all conditions, the shortest road braking distance meets the **best performance**
- A broad range of **accessories and installation kits** to ensure problem-free installation
- **ECE-R90 homologation**. Technical contents OE like
- Adoption of **advanced solutions** patented by Brembo to minimize noise and vibrations



BREMBO PRIME CERAMIC

- **Maximum driving comfort**
- Reduced friction wear and **low dust emission**, that means aesthetically beautiful rims of the wheel and less maintenance
- Advanced friction materials in line with the most severe **environmental** standards
- **Copper free**



SPECIAL SOLUTIONS

The exclusive solutions are used to improve both the **performance** and **comfort** of the brake system:

- Damping weights, used to minimize brake noises
- Directional pads, that indicate the correct side for fitting the pad, in order to maximize comfort, wear and performance
- Scorching treatment, to increase the fading resistance



PRIME DISCS AND PADS FOR COMMERCIAL VEHICLES

BREMBO PRIME DISCS

A full range of standard, Co-Cast and Ring brake discs. Co-Cast and Ring discs offer **advanced technical features** for:

- Superior mechanical resistance
- Better heat dissipation and thermal crack reduction
- Greater safety
- Longer life of discs and pads

The Ring disc is designed to help the brake discs maintenance, allowing the replacement of the braking surface without replacing the entire hub. The discs package comes complete with spacer, screws, and metallic ring for the ultimate **easy fit replacement**.



BREMBO PRIME PADS

Braking performance is not only dependent on the disc but is directly affected by the brake pads. The brake discs and pads used in Brembo brake systems are designed to work together.

Brembo range of commercial vehicle pads is composed by 18 different friction materials, used to meet the different needs of use. Each compound is made of 30 different components, designed to meet the performance required by a heavy-duty vehicle.



ProTecS® By Knorr-Bremse

ProTecS® technology consists of brake pad backplate and pad holder spring connected by a welded hood.

ADVANTAGES:

- Accurate usage of the spring's elasticity and optimal guidance of the brake pads
- Increase of the life expectancy of the brake pads, especially on rough roads
- The brake pad slides back more easily from brake disc contact, reducing the risk of brake pad wear when the brake is released
- No risky re-use of springs
- Secure retention of pad spring



PRIME CALIPERS FOR LIGHT COMMERCIAL VEHICLES

Brembo Prime brake calipers are specifically designed for light commercial vehicles. Each product is manufactured and tested in Brembo European plants and designed to ensure maximum performance levels, **reliability and durability**.

For the majority of vehicles selected, the caliper can be combined with the Brembo **bracket**, for a complete and safe servicing of the braking system.

Brembo aftermarket calipers range covers all the applications with Brembo OE calipers.



PRIME BRAKE FLUID

Superior product and premium design, for a maximum performance and safety

Brembo Prime Brake Fluid range exceeds the standards for class 4, 5.1 and 6 brake fluid, guaranteeing **safe braking**, **reduced viscosity** and high boiling point.

Available in bottle or tank of 0,25 l - 0,5 l - 1 l - 5 l - 20 l



DOT 3

Excellent corrosion protection of braking system and all metal alloys and compatibility with rubber components to enable long durability of the braking system.

DOT 4

Very high boiling point and lower viscosity than the DOT standard, which fully satisfies the regulation, and even goes over its standards.

DOT 4 LOW VISCOSITY

DOT 4 LV ensures an immediate answer of the ESP device. This is the best choice for most of the modern vehicles, equipped with electronic stability and braking control systems (ABS, ESP, ACR, TCS...). It is also the most suitable for use on electric vehicles.

DOT 5.1

Superior features in terms of resistance to high temperatures and viscosity. Recommended for high-performance vehicles, including models equipped with ABS.

BEYOND LINE

SOLUTIONS LINE • INNOVATIONS FOR THE NEW MOBILITY

BEYOND EV KIT FOR ELECTRIC VEHICLES

Since electric vehicles have extremely specific braking requirements, any braking system must fulfill a series of crucial demands. It must be corrosion resistant, silent in operation, light in design and reduce residual torque.

Brembo is the first manufacturer of braking systems that, in addition to producing a special copper free friction material dedicated to electric cars, offers a specific solution that also includes a disc with a special anti-corrosion treatment on the braking surface, that lasts over time. The end result is a braking system that guarantees **efficient performance and protection from rust beyond 100,000 km** even in the toughest conditions of use.



BREMBO BEYOND GREENANCE KIT

Brembo Beyond Greenance kit consists of a special alloy disc which guarantees high resistance to wear and a pad with a compound developed for use in combination with the Greenance disc.

Brembo Beyond Greenance Kit combines **maximum braking** performance with a **lower environmental impact**, while increasing the **life** of the discs.

The product ensures a significant reduction of emissions during braking, ahead of requests regulations of the new Euro 7: **-83% of PM10 and -80% of PM2.5.**

Greenance kit has passed the ECE-R90 tests and the most strict bench and on-road tests conducted by the R&D department, which have highlighted a longer life of the Greenance brake discs compared to the standard discs in the aftermarket.

This leads to an important decrease in the total cost of ownership, which is a priority for professionals that travel many kilometers with their vehicle.

THE TARGET

Greenance kit is available for most popular light commercial vehicle models on the market.

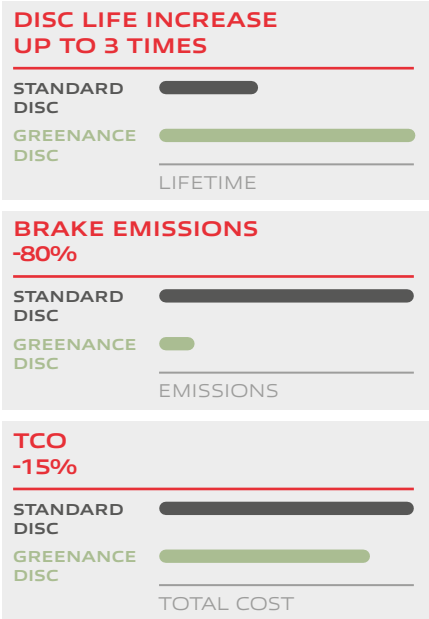

XTRA LINE

COOL LINE • DISTINCTIVE PERFORMANCE

THE PERFECT DISCS & PADS MATCH

Brembo Xtra pads have been developed to enhance the advantages offered by Brembo Xtra and Max discs.

The Xtra range matches the expectation of the most enthusiast road drivers, through the perfect synthesis between **performance, pedal feeling and comfort.**

XTRA BENEFITS

- Greater grip
- Cleaning and renewing of the pads
- Superior performance on wet roads
- Maximum friction even at high temperature
- Cooling of the brake system
- No compromise with safety
- Iconic design, for stylish sport appearance



MAX BRAKE DISCS

THE SLOTTED SOLUTION

Brembo Max are slotted and UV coated discs that provide superior braking performance in all conditions, optimizing road performance and ensuring continuous renewal of the friction material.



XTRA BRAKE DISCS

THE DRILLED SOLUTION

A specific drilling combines the attractive aesthetic look - enhanced by the exclusive UV painting - with brilliant and efficient performance in any braking conditions, in order to emphasise the driving style of true enthusiasts.

GREATER GRIP

Compared to standard brake discs, the shape of Brembo Xtra & Max guarantees, in the initial stages of braking, a better grip, obtained thanks to a higher coefficient of friction: this ensures shorter and more effective braking, thanks to a quicker and more responsive pedal and a more immediate braking attack.

SLOTTED OR DRILLED? WHAT IS THE BEST SOLUTION?

	MAX	XTRA
GREATER GRIP DURING THE BRAKING	✓	✓
CLEANING AND RENEWING THE PADS	✓	✓
SUPERIOR PERFORMANCE ON WET ROADS	✓	✓
MAXIMUM FRICTION EVEN AT HIGH TEMPERATURES	✓	✓
BETTER COOLING OF THE BRAKE SYSTEM	-	✓
MAXIMUM SAFETY IN ALL SITUATION	✓	✓
MAXIMUM RESISTANCE TO CORROSION	✓	✓
EASY CONTROL OF WEAR	✓	-

XTRA BRAKE PADS

NEW COPPER FREE MATERIAL

With more than 30 different components, the innovative copper free compound is the result of Brembo's experience in top segment of OE.

Developed on luxury cars and tested also on mid segment vehicles to exceed driving enthusiasts' expectations, it ensures the best driving performance also in terms of comfort and mileage.



RIGOROUSLY TESTED FOR MAXIMUM SAFETY

Comparison tests carried out between Brembo Xtra range against the representative competitor offering of drilled/grooved discs and pads combinations, from several different suppliers within the aftermarket, confirm the range is the exclusive technical solution and is manufactured to pass the most demanding road and bench tests for unparalleled safety guaranteed.

THE PERFECT COMBINATION

PERFORMANCE

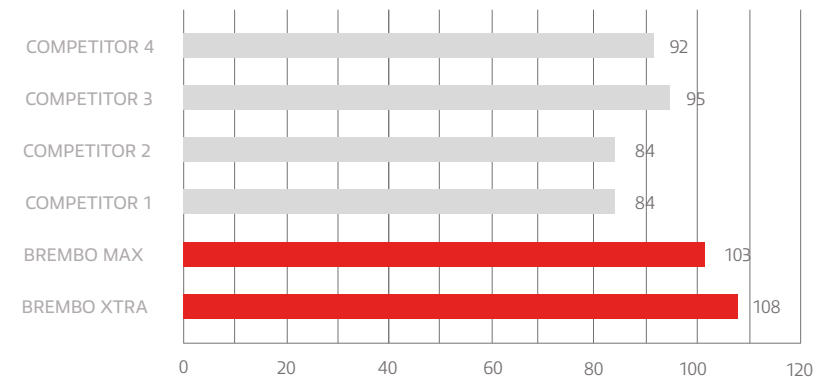

XTRA CERAMIC BRAKE PADS

Xtra ceramic pads are ideal for top end cars. They guarantee top performance, clean rims and comfort.





DEMAND XTRA

SUPERIOR STYLE, EXTRA PERFORMANCE

Expertly engineered by Brembo. Disc and pad have been developed to work perfectly together enhancing braking capability and delivering the pleasure of sports performance in every drive.

Demand Xtra. Get more.

CALIPER X-STYLE

An extension of Brembo's globally renowned, iconic caliper made with the same OE quality and excellence you can count on.

Brembo calipers X-Style are available in dedicated **kit solutions**, which include two calipers (left and right) and two sets of accessories (springs and pins).

Multi colour options and other different colours on demand.

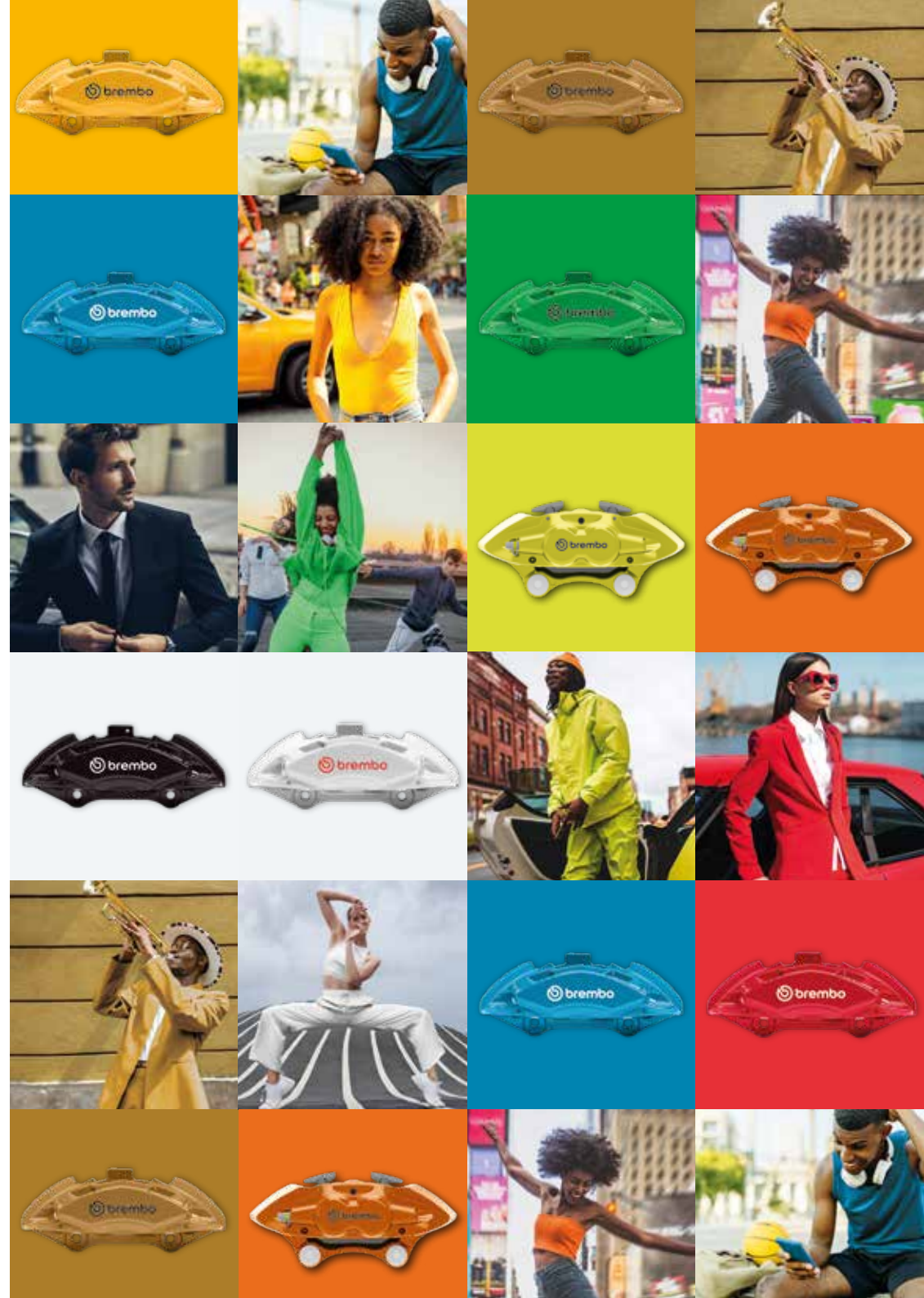

ESSENTIAL LINE

STANDARD LINE • BREMBO QUALITY FOR THE ENTIRE BRAKE SYSTEM

DRUMS, SHOES AND SHOE KITS

Brembo offers a wide range of brake drums, shoes and shoe kits. Shoe kits are available in two different versions: standard kit and kit&fit.

The kit includes all the components necessary for the maintenance of drum brakes:

- 2 pairs of shoes
- 2 brake wheel cylinders
- Adjusters
- Springs
- Lubricant
- Fixing kit



REMANUFACTURED CALIPERS

Designed to provide the same performances of new brake calipers, the Brembo **remanufactured calipers** identify an alternative solution to the replacement of faulty calipers with new ones. Caliper body recycling is an eco-friendly choice.

The remanufacturing process includes:

- testing and cleaning of the caliper;
- full replacement of parts subject to wear with new components;
- surface coating with a particular corrosion-proof layer.

After undergoing an inspection, the calipers are marked with an incision to indicate the regeneration, so that they are not subjected to future remanufacturing. They are supplied ready for assembly.



BRAKE CALIPER REPAIR KIT

This important component of the braking system features some internal parts which can wear and deteriorate with time. Now these components can be replaced with new Brembo quality components, to ensure the brake calipers continue to work in **total safety** and to ensure **maximum performance** levels for the braking system.

Spare parts professionals can choose between 5 different families of Brembo kits:

- Guide sleeve kit
- Piston seals
- Repair kit
- Piston





[bremboparts.com](https://www.bremboparts.com)